

iConverter® 4xT1/E1 MUX/M Managed T1/E1 Multiplexer

The iConverter 4xT1/E1 MUX/M multiplexes up to four T1/E1s and Ethernet onto a 1000Mbps fiber optic transport link, and features remote management testing and configuration capabilities.

The iConverter 4xT1/E1 MUX/M operates in a back-to-back configuration, with one multiplexer at each end of the fiber transport link. The 4xT1/E1 MUX/M can be used in applications where services from legacy TDM equipment require transport across long distances that exceed the reach or capacity of copper. This includes applications such as T1/E1 extension, mobile backhaul and building-to-building PBX connectivity, making it ideal for Enterprise, Telecom and Utility industries.

The 4xT1/E1 MUX/M supports 1000Mbps Small Form Pluggable (SFP) transceivers, enabling adaptability to different fiber types and distances, and support CWDM and DWDM technology to increase the bandwidth capacity of fiber infrastructure.

The 4xT1/E1 MUX/M fixed fiber models support multimode and single-mode dual fiber with ST, SC and LC connectors; and single-mode single-fiber with SC connectors.

The copper interfaces feature four RJ-48 connectors for balanced T1/E1 applications. An optional adapter cable is available to convert each RJ-48 interface to a BNC interface for unbalanced E1 transport applications.

The 4xT1/E1 MUX/M supports AMI, B8ZS and HDB3 line codes. DIP-switches provide easy configuration of the T1/E1 line codes and line build-out.

The 4xT1/E1 MUX/M features user-selectable local loop-back on both the copper and fiber ports, remote fiber loop-back and circuit test modes. These functions facilitate diagnosis of the remote unit, and minimizes the need for test equipment and support personnel at each end of a link. Alarm relay and LEDs provide fault notification for loss of power, LOS and AIS.

Configuration of T1/E1 line codes, line build out, loopbacks and circuit test is accomplished via local serial port, Telnet, SNMP or DIP-switches.

The 4xT1/E1 MUX/M is a compact, managed standalone unit available in both AC and DC models. The AC model accepts AC power input ranging from 100VAC to 240VAC, 50/60Hz, while the DC model accepts +/- 18VDC to 60VDC.



SFP not included

KEY FEATURES

- Multiplexes four independent T1 or E1 channels from copper links into one fiber link
- 10/100/1000 copper Ethernet multiplexed with T1/E1 circuits
- Ethernet port supports 10/100/1000 and Half/Full-Duplex auto-negotiation and MDI/MDIX auto-crossover
- 1000Mbps Small Form Pluggable (SFP) transceivers with Optical Statistics for standard, CWDM or DWDM applications
- Fixed-fiber connectors support multimode, single-mode dual fiber with ST, SC and LC connectors, and single-mode single-fiber with SC connectors
- Supports AMI, B8ZS and HDB3 line codes
- Easy configuration of T1/E1 line codes and line build-out
- Configurable alarm relay contacts for audio/visual fault notification
- Supports local and remote fiber and copper loop-back modes
- Remotely-managed configuration and testing enables rapid deployments
- Management via local serial port, Telnet or SNMP
- SNMP management via NetOutlook® provides real-time port and module status information, configuration and trap notification
- Commercial (0 to 50° C) and wide (-40 to 60° C) operating temperature ranges
- TAA, BAA and NDAA Compliant, and Made in the USA
- Lifetime Warranty and free 24/7 Technical Support

APPLICATION

Mobile Backhaul

The following application shows an example of the iConverter 4xT1/E1 MUX/M used in a hybrid TDM/Ethernet transport network.

A wireless service provider has enhanced their network to support 3G/4G services. The new equipment uses Ethernet for backhaul at the Cell Site, while their existing legacy 2G equipment uses TDM (T1) for backhaul.

At the Base Station Controller (BSC) and Radio Network Controller (RNC), an iConverter 4xT1/E1 MUX/M is installed

to extend the TDM and IP Networks to the Cell Site. The service provider is able to multiplex up to 4 T1/E1 circuits and one 10/100/1000 Ethernet service on a common fiber link.

The fiber carries the multiplexed traffic to a second iConverter 4xT1/E1 MUX/M installed at the Cell Site where the T1/E1 circuits and Ethernet service provides connectivity to the equipment at the site.

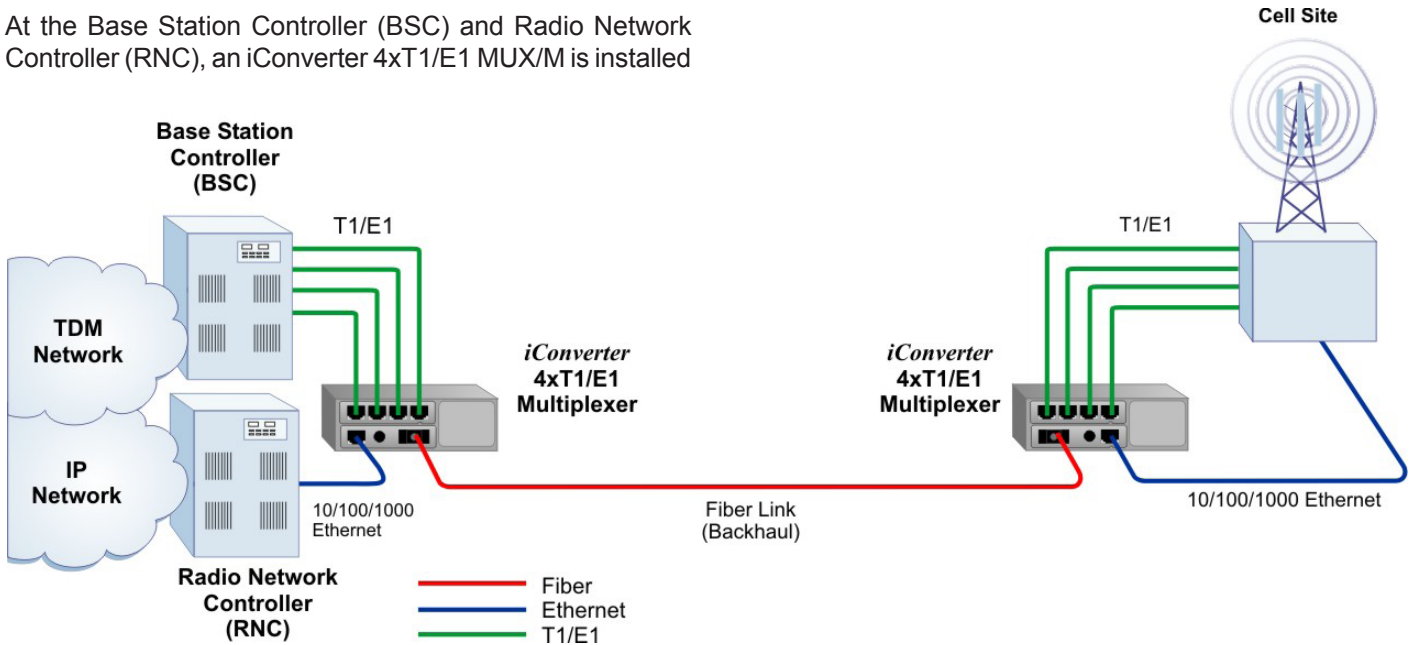

SPECIFICATIONS

Description	<i>iConverter 4xT1/E1 MUX/M</i>	
Data Rates	T1 / ISDN PRI:	1.544Mbps
	E1:	2.048Mbps
	Ethernet:	10/100/1000 (900Mbps max)
Standard Compliances	ANSI:	T1.403, T1.102,
	AT&T:	T62411,
	ITU:	G.703, G.704, G.706, G.736, G.755, G.823, G.824, G.8261,
	ETSI:	ETS 300 166,
	IEEE:	802.3
Regulatory Compliances	Safety:	UL, CE, UKCA
	EMI:	FCC Class A
	ACT:	TAA, BAA, NDAA
Environmental	RoHS, WEEE, REACH	
Port Types	Copper:	T1/E1 (RJ-45/RJ-48) 10/100/1000BASE-T (RJ-45)
	Fiber:	1000Mbps (ST, SC, Single-fiber SC, SFP)
Cable Types	Copper:	Cat 3 or higher for T1/E1 (T1: 100 Ohm, E1: 120 Ohm) (Active Pairs are Pins 1, 2 and 4, 5) EIA/TIA 568A/B, Cat 5 or higher for Ethernet
	Fiber:	Multimode: 50/125µm, 62.5/125µm Single-mode: 9/125µm

Management	IPv4 address, Telnet, SNMPv1/v2c/v3 In-Band via Ethernet port, Out-of-band via serial port	
Frame Size	Ethernet:	Up to 10,236 bytes
AC Power Requirements	AC Input:	100 to 240VAC 50/60Hz 0.5A @ 120VAC IEC 320 Socket
	DC Input:	+/- 18 to 60VDC; 2.0A @ 48VDC 3-Pin Terminal (isolated)
Dimensions W x D x H	6.7" x 5.51" x 1.87" (170.18 mm x 139.95 mm x 47.5 mm)	
Weight	2.5 lb (1.14 kg)	
Temperature	Commercial:	0 to 50°C
	Wide:	-40 to 60°C
	Storage:	-40 to 80°C
Humidity	5 to 95% (non-condensing)	
Altitude	-100m to 4,000m	
MTBF (hrs)	AC Model:	137,000
	DC Model:	148,000
Warranty	Lifetime warranty with 24/7/365 free Technical Support	

ORDERING INFORMATION

Step 1: Choose the Base Part Number (xxxxN-x-pt)

Fiber Type	Distance	Connector Type			Tx / Rx Lambda (nm)	Min. Tx Power (dBm)	Max. Tx Power (dBm)	Min. Rx Power (dBm)	Max. Rx Power (dBm)	Min. Attenuation (dB)	Link Budget (dB)
		ST	SC	SFP							
-	-	-	-	8839N-0-pt	-	-	-	-	-	-	-
MM/DF	220/550m ¹	8820N-0-pt	8822N-0-pt	-	850 / 850	-10	-4	-17	-3	-	7
SM/DF	12km	8821N-1-pt	8823N-1-pt	-	1310 / 1310	-9.5	-3	-19.5	-3	-	10
SM/DF	34km	-	8823N-2-pt	-	1310 / 1310	-5	0	-23	-3	3	18
SM/DF	80km	-	8823N-3-pt	-	1550 / 1550	-5	0	-23	-3	3	18
SM/DF	110km	-	8823N-4-pt	-	1550 / 1550	0	5	-24	-3	8	24
SM/DF	140km	-	8823N-5-pt	-	1550 / 1550	2	5	-28	-8	13	30
SM/SF ²	20km	-	8830N-1-pt	-	1310 / 1550	-9.5	-3	-20	-3	-	10.5
SM/SF ²	20km	-	8831N-1-pt	-	1550 / 1310	-9.5	-3	-20	-3	-	10.5
SM/SF ²	40km	-	8830N-2-pt	-	1310 / 1550	-3	0	-20	-3	3	17
SM/SF ²	40km	-	8831N-2-pt	-	1550 / 1310	-3	0	-20	-3	3	17

¹ 62.5/125µm, 100/140µm multimode fiber up to 220m. 50/125µm multimode fiber up to 550m.

² When using single-fiber (SF) models, the Tx wavelength on one end has to match the Rx wavelength on the other.

MM = Multimode, SM = Single-mode, DF = Dual Fiber, SF = Single-fiber

Contact Omnitron for other fiber options and operating temperature ranges.

Order the appropriate 1000Mbps SFPs separately. [Visit the Omnitron Optical Transceivers web page.](#)

Step 2: Choose your Power Option (xxxxN-x-pt)

B = AC Power Supply, 100 to 240VAC 50/60Hz, with IEC 320 Socket
C = Direct DC Power Supply, +/- 18 to 60VDC, with 3 Pin Terminal (isolated)

Step 3: Choose an Operating Temperature Range (xxxxN-x-pt)

<leave blank> = Commercial temperature (0 to 50°C)
W = Wide temperature (-40 to 60°C)

ACCESSORIES

Model Number	Description
9140-3	RJ-48 to Coax Adapter Cable (3 meters)
9142-1	RJ-48 Alarm Breakout Cable
8249-0	Wall / Rack Mount Hardware Kit
8260-0	19" Rack Mount Shelf (up to two T1/E1 Muxes)

©2023 Omnitron Systems Technology, Inc. All rights reserved. iConverter and NetOutlook are registered trademarks of Omnitron Systems Technology, Inc. Trademarks are owned by their respective companies. Specifications subject to change without notice.

