

iConverter® xFF **Industrial SFP to SFP Protocol-Transparent Fiber Convert**

The iConverter xFF is an industrial protocol-transparent media converter and transponder that is available as a compact, unmanaged standalone unit or a managed chassis plug-in module. The iConverter xFF provides reliable and cost-effective conversion between different wavelengths, multimode and single-mode, and dual and single-fiber.

The iConverter xFF operates as a protocol and rate-transparent device, supporting Small Form Pluggable (SFP) transceivers with data rates from 1Mbps to 8.50Gbps. The xFF supports a variety of network protocols, including Ethernet, Fast Ethernet, Gigabit Ethernet, SONET (OC-3/12/48), SDH (STM-1/4/16), 1x/2x/4x/8x Fibre Channel and Common Public Radio Interface (CPRI).

The iConverter xFF supports multimode and single-mode dual fiber; and single-mode single-fiber SFP transceivers. SFPs allow adaptability to different fiber types, distances and wavelengths, providing maximum flexibility across a variety of network architectures and topologies. The xFF media converter can utilize a variety of SFPs for different wavelengths and distances, reducing costs and simplifying inventories.

SFP transceivers enable the xFF to operate as a Coarse Wave Division Multiplexing (CWDM) or Dense Wave Division Multiplexing (DWDM) transponder, which converts an optical signal from legacy fiber equipment to a specific CWDM/DWDM wavelength. Wave division technology increases the bandwidth capacity of the fiber infrastructure by overlaying multiple signals, each using a different wavelength, over an existing fiber link.

There is no configuration required with the plug-and-play iConverter xFF. Connect the fiber cables to the appropriate interface and the installation is complete.

The xFF features user-selectable Link Propagate and Remote Fault Detection modes to facilitate quick fault detection, isolation and reporting.

The hot-swappable, plug-in module can be mounted in a 19 or 5-Module chassis with redundant DC power supplies. It can also be mounted in a 2-Module DC powered chassis, or in a 1-Module chassis with DC power input.

The standalone iConverter xFF is an unmanaged wall-mount unit. The wall-mount models are DC powered and are available with an external AC to DC power adapter, or a terminal connector for DC power.



SFPs not included

KEY FEATURES

- Industrial SFP to SFP protocol-transparent fiber converter
- Industrial operating temperature range (-40 to 75°C)
- Supports Ethernet, Fast Ethernet and Gigabit Ethernet
- Supports SONET (OC-3/12/48) and SDH (STM-1/4/16)
- Supports 1x/2x/4x/8x Fibre Channel
- Supports Common Public Radio Interface (CPRI) line rates up to 6.144Gbps
- Compatible with T1/E1, DS3/T3/E3, serial multiplexers and media converters from Omnitron
- Supports SFP Digital Diagnostic Monitoring Interface (DDMI) bus
- Provides multimode to single-mode and dual to single-fiber media conversion
- Provides wavelength conversion for CWDM/DWDM applications
- User-selectable link fault detection modes facilitate quick fault detection, isolation and reporting
- LED displays for immediate visual status of each port
- Management of the plug-in module is available with the addition of a management module to the chassis
- SNMP management via NetOutlook® provides real-time module status information and trap notification of plug-in module
- Made in the USA
- Lifetime Warranty and free 24/7 Technical Support

APPLICATIONS

Multimode to Single-mode Conversion

Networks often require conversion from multimode to single-mode fiber, which supports longer distances. In this application, two Ethernet switches equipped with

multimode fiber ports are connected utilizing a pair of fiber-to-fiber converters which convert the multimode fiber to single-mode and enable network connectivity across the distance between the switches.

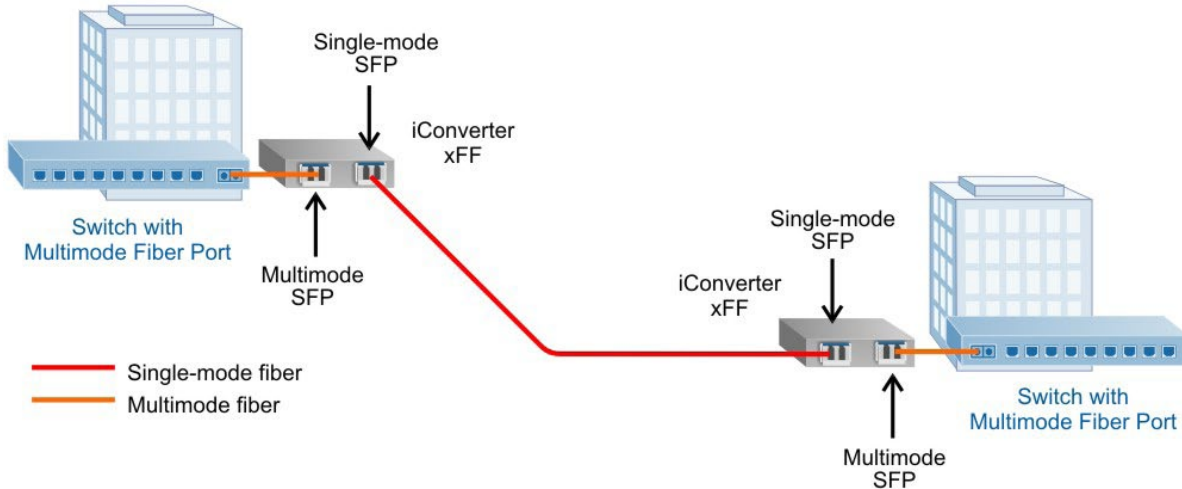

CWDM Transponder

Fiber optic communications equipment with fixed fiber interfaces (ST, SC or LC connectors) operating over legacy wavelengths (850nm, 1310nm, 1550nm) must be converted to CWDM wavelengths using a media converter configured as a transponder.

The iConverter xFF is SFP to SFP protocol-transparent fiber converter and transponder, designed to provide conversion between different wavelengths, multimode and single-mode, dual fiber and single-fiber.

In this example, an Ethernet switch with a fixed fiber uplink port needs to be connected to an iConverter CWDM/X Multiplexer. An iConverter xFF transponder module is used

to convert the fixed fiber wavelength from the Ethernet switch to a specific CWDM wavelength required by the CWDM/M Multiplexer.

Two SFP transceivers are required in this application. The left side of the transponder uses a 1310nm standard SFP transceiver, while the right side of the transponder uses a 1530nm CWDM SFP transceiver. The CWDM SFP installed in the transponder is connected to a channel port on the iConverter CWDM/X Multiplexer.

The iConverter xFF converts the legacy 1310nm wavelength to CWDM 1530nm wavelength allowing the Ethernet switch to be connected to the Multiplexer.

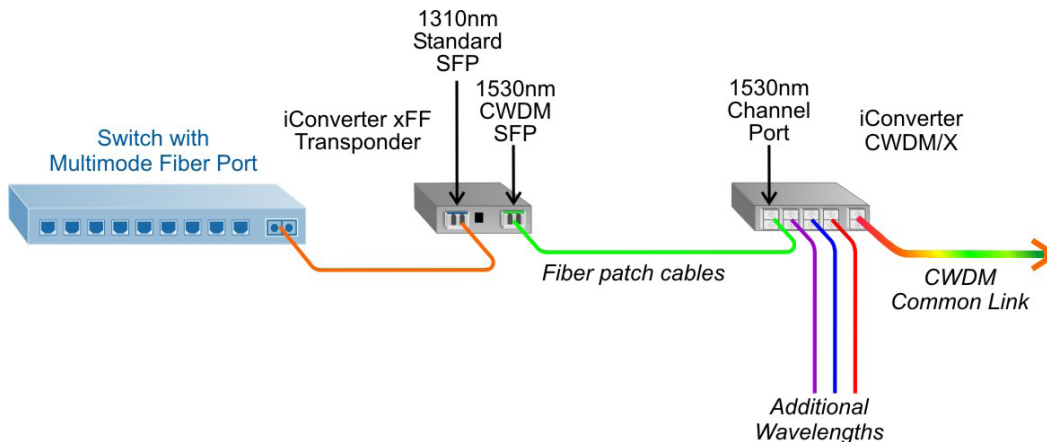

MANAGEMENT

The iConverter xFF plug-in module can be used in managed or unmanaged applications. Management provides remote configuration, monitoring and trap notification. Management of the xFF plug-in module is accomplished by installing an iConverter Management Module or Network Interface Device (NID) in the same chassis.

The Management Module can be accessed via SNMP, Telnet, and serial port. The xFF can be managed with Omnitron's intuitive, graphic-oriented NetOutlook SNMP Management Software or third party SNMP management software. Management via the Telnet and the serial interfaces have an easy-to-use, menu-driven interface.

The management software can override the physical DIP-switch settings such as link modes. Some of the real-time xFF parameters that can be monitored include power, link, data activity status, module type and model, hardware and software revisions, serial numbers and a user-defined identifier.

The iConverter xFF supports SNMP trap notification for the monitoring and notification of different network events. Specific events that generate traps include module insertion and removal, and port link-up and link-down. Trap monitoring of specific events can be selectively enabled or disabled by the network management software.

SPECIFICATIONS

Description		<i>iConverter</i> xFF	
Description		SFP to SFP Protocol-Transparent Fiber Converter	
Standard Compliant		Protocol Transparent up to 8.50Gbps: Ethernet (100BASE-X, 1000BASE-X) SONET (OC-3, OC-12, OC-48), SDH (STM-1, STM-4, STM-16) Fibre Channel (1x, 2x, 4x, 8x), CPRI line rates (up to 6.144Gbps)	
Compatible Applications		T1/E1, DS3/T3/E3, RS232, RS422, RS485, X.21	
Regulatory Compliant		UL, CE, FCC Class A, RoHS, WEEE, REACH	
Frame Size		Unlimited	
Port Types		Fiber:	Protocol Transparent (SFP)
Cable Types		Fiber:	Multimode: 50/125µm, 62.5/125µm Single-mode: 9/125µm
AC Power Requirements		AC Adapter:	100 - 240VAC/50 - 60Hz 0.05A @ 120VAC
DC Power Requirements		DC Input: (Backplane)	3.3VDC, 0.5A @ 3.3VDC
		DC Input: (Terminal Block)	5 - 32VDC, 0.3A @ 9VDC (1.0A max) 2-Pin Terminal (non-isolated)
		DC Input: (AC Adapter)	5 - 32VDC, 0.3A @ 9VDC (1.0A max) 2.5mm Barrel Connector
Dimensions (W x D x H)		Plug-in:	0.85" x 4.5" x 2.8" 21.6 mm x 114.3 mm x 71.1 mm
		Standalone:	3.8" x 4.8" x 1.0" 96.5 mm x 121.9 mm x 25.4 mm
Weight		Plug-in:	8 oz.; 226.8 grams
		Standalone w/o Adapter:	1.0 lb.; 453.6 grams
		Standalone w Adapter:	1.5 lbs.; 680.4 grams
Temperature		Industrial:	-40 to 75°C
		Storage:	-40 to 80°C
Humidity		5 to 95% (non-condensing)	
Altitude		-100m to 4,000m	
MTBF (hrs)		Plug-in:	1,300,000
		Standalone w/o Adapter:	1,200,000
		Standalone w/ US Adapter:	250,000
		Standalone w/ Uni Adapter:	100,000
Warranty		Lifetime warranty with 24/7/365 free Technical Support	

ORDERING INFORMATION

Model Number	Description
8699-0-pZ	SFP to SFP Protocol-Transparent Fiber Converter
Power Options (p):	
<leave blank> = Plug-in module	
D = Barrel Connector and AC/DC Power Adapter 100-240VAC, 50-60Hz, with US power cord, with integrated mounting brackets	
E = Barrel Connector and Universal AC/DC Adapter, 100 - 240 VAC, 50-60Hz, No Power Cord, with integrated mounting brackets	
F = Direct DC input, 2 pin terminal connector, no AC/DC power adapter, with integrated mounting brackets	
J = Barrel Connector and JPN PSE AC/DC Adapter, 100 - 240 VAC, 50-60Hz, No Power Cord, with integrated mounting brackets	
Operating Temperature:	
Z = Extended temperature (-40 to 75°C)	
Contact Omnitron for other fiber options. Order the appropriate SFPs separately. Visit the Omnitron Optical Transceivers web page.	
See chassis and mounting options at: iConverter Chassis and Mounting Option web page.	

© 2021 Omnitron Systems Technology, Inc. All rights reserved. *iConverter* and *NetOutlook* are registered trademarks of Omnitron Systems Technology, Inc. Trademarks are owned by their respective companies. Specifications are subject to change without notice.

