

FlexPoint GX/T 10/100/1000 UTP to 100/1000X Ethernet Media Converter

The FlexPoint GX/T is a 10/100/1000BASE-T UTP to 1000BASE-X modular fiber media converter that supports jumbo frames up to 10,240 bytes. The GX/T features Small Form Pluggable (SFP) transceivers that support both 100BASE-FX and 1000BASE-X for interoperability with Gigabit and Fast Ethernet fiber equipment. SFP transceivers enable adaptability to different fiber types, speed and distances, and support Coarse Wave Division Multiplexing (CWDM) technology to increase the bandwidth capacity of fiber infrastructure.

The FlexPoint GX/T also supports SC and ST fixed fiber connectors for multimode, single-mode fiber; and single-mode single-fiber models are available.

Both the fiber port and the UTP port support auto-negotiation, an IEEE standard which defines how all the communicating devices automatically perform their configuration functions. Auto-negotiation achieves the best possible mode of operation (speed, duplex mode and Pause mode) between the devices.

The auto-negotiation feature can be disabled on both ports (for manual configuration) using DIP-switches on the product. This is useful in a situation where the GX/T is connected to a non-negotiating device and the configuration parameters must be set manually.

Network flow control is managed by the Pause function (configured via auto-negotiation or manually) that prevents network congestion on both the UTP and fiber ports. When Pause is enabled and the device is experiencing network congestion, it will send out a Pause signal to its link partner, instructing it to slow down data transmission.

A variety of testing and fault detection tools are provided for easy installation and troubleshooting. The GX/T supports Port Loop-Back, IEEE defined Far-End-Fault and Link Fault bit as Remote Fault indicators. The GX/T generates a remote fault indicator when it detects link fault conditions, and reports detection of these signals by displaying status on the LED. Through user DIP-switch configuration, the detection of these indicators or link modes can also be propagated to the other port on the GX/T as a means of notifying connected end-devices of the link fault.

Diagnostic data is provided through LED indicators that assist in network installation and maintenance. The LEDs report the availability of power, port activity and link status and duplex mode.

The GX/T supports a wide input voltage range of 5 to 32VDC for flexibility to power the device from a variety of sources.

GX/T modules can be standalone or surface-mounted utilizing optional wall-mounting hardware or DIN-rail mounting brackets. They can also be rack-mounted in a 5-Module shelf or in a high-density 14-Module, power-redundant chassis.



KEY FEATURES

- The FlexPoint GX/T is a 10/100/1000 copper to 100/1000* modular fiber media converter
- Conforms to 10BASE-T, 100BASE-TX, 1000BASE-T, 100BASE-FX* and 1000BASE-X specifications
- Fiber port supports multimode and single-mode fiber with ST and SC connectors and single-fiber with SC connectors
- Supports dual fiber and single-fiber 100BASE-FX or 1000BASE-X SFP transceivers for standard or CWDM wavelengths
- Both the fiber and UTP ports support auto-negotiation
- Provides Remote Fault Indicators to signal loss of link for Far-End Fault and Link Fault conditions
- UTP port supports 10/100/1000Mbps and Half/Full-Duplex
- Auto or manually configured Pause function for flow control
- Supports jumbo frames up to 10,240 bytes
- Loopback mode supports end-to-end testing
- User-selectable Link Modes for quick fault detection
- Diagnostic and DIP-switch configurations are displayed with status LEDs for quick and easy installation
- Tabletop, wall-mounted, rack-mounted in a 5-Module shelf or in a 14-Module power-redundant chassis options
- Lifetime Warranty and free 24/7 Technical Support

* 100BASE-FX is supported on SFP models only

SPECIFICATIONS

Model Type	GX/T		
Protocols	IEEE 802.3 10BASE-T, 100BASE-TX, 1000BASE-T, 100BASE-FX, 1000BASE-X		
Frame Size	10,240 bytes maximum frame size		
UTP Cable	RJ-45, Category 5 and higher		
Fiber Cables	Multimode: 50/125, 62.5/125, 100/140µm Single-mode: 9/125µm		
UTP Connectors	RJ-45		
Fiber Connectors	ST, SC, LC (SFP)		
DIP-Switches	Fiber: Auto-Neg, 1000, 100 UTP: Auto-Neg, 10, 100, 1000, FDX/HDX, Pause En/Dis Loopback, Link Seg, Link Prop, Remote Fault Det.		
LED Displays	Power, Fiber AN, Fiber Speed/Activity, UTP Speed/Activity, Full/Half-Duplex		
Dimensions	W: 3.0" x D: 4.0" x H: 1.0"		
Weight	6 oz. (without power adapter)		
Compliance	UL, CE, FCC Class A		
Power Requirements	Nominal Voltage:	Barrel Connector	Molex Connector
	Voltage Range:	9VDC	5VDC
	Power Nominal:	5.0 to 15.0VDC	5.0 to 5.25VDC
	Maximum Power:	0.3A @ 9VDC	0.5A @ 5VDC
		1A @ 9VDC	0.75A @ 5VDC
Temperature Operating:	0 to 50° C		
Storage:	-40 to 80° C		
Humidity	5 to 95% (non-condensing)		
Altitude	-100m to 4000m		
MTBF (Hours)	Module without Power Adapter: 900,000 Module with Power Adapter -1: 250,000 Module with Power Adapter -2: 100,000		

APPLICATION EXAMPLE

In this enterprise application example, FlexPoint GX/T media converters are used to connect to multiple generations of networking components across a campus. A legacy 100 Mbps fiber switch (A) is directly connected to a UTP Gigabit switch using a FlexPoint GX/T with a 100 Mbps SFP transceiver installed. A fiber-to-desktop application (B) uses a FlexPoint GX/T at both ends to provide 10/100/1000 copper to fiber conversion. The FlexPoint GX/T also connects a UTP Gigabit Ethernet switch (C) via fiber back to the main distribution center. In all cases, multimode, single-mode, or single-mode single-fiber can be used.

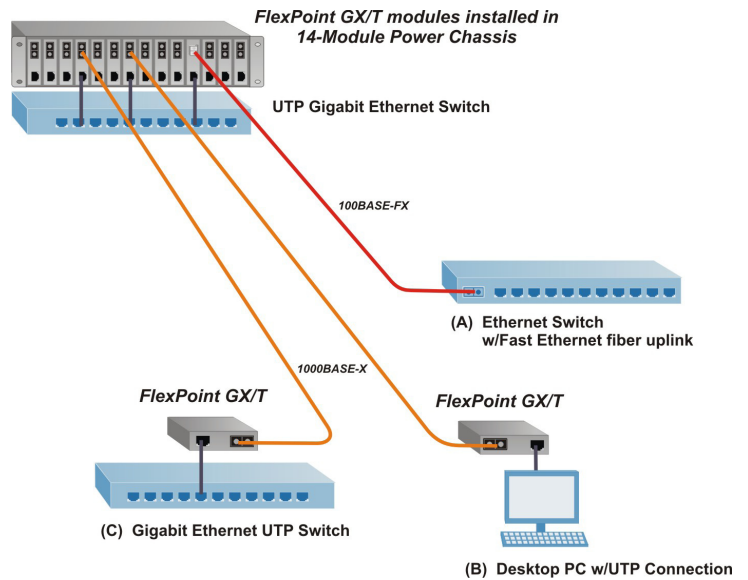

ORDERING INFORMATION



Fiber Type	Distance	Connector Type			Tx / Rx Wavelength [nm]	Min. Tx Power (dBm)	Max. Tx Power (dBm)	Min. Rx Sensitivity (dBm)	Max. Rx Sensitivity (dBm)	Min. Attenuation (dB)	Optical Power Budget
		ST	SC	SFP							
-	-	-	-	4719-x							
MM	220 / 550m ¹	4706-x	4700-x	-	850	-10	-4	-17	-3	-	7
SM	12km	4707-x	4701-x	-	1310	-9.5	-3	-19.5	-3	-	10
SM	34km	-	4702-x	-	1310	-5	0	-23	-3	3	18
SM	80km	-	4703-x	-	1550	-5	0	-23	-3	3	18
SM	110km	-	4704-x	-	1550	0	5	-24	-3	8	24
SM	140km	-	4705-x	-	1550	2	5	-28	-8	13	30
SM-SF	20km	-	4710-x ♦	-	1310/1550	-9.5	-3	-20	-3	-	10.5
SM-SF	20km	-	4711-x ♦	-	1550/1310	-9.5	-3	-20	-3	-	10.5
SM-SF	40km	-	4712-x ♦	-	1310/1550	-3	0	-20	-3	3	17
SM-SF	40km	-	4713-x ♦	-	1550/1310	-3	0	-20	-3	3	17

Power Adapter Kits (-x): -0 = No power adapter included, -1 = 110-120 VAC/60 Hz (US plug), -2 = 100-240 VAC/50-60 Hz (IEC plug, no power cord).

Contact Omnitron for other fiber options and operational temperature ranges.

¹ = 62.5/125µm, 100/140µm multimode fiber up to 220m. 50/125µm multimode fiber up to 550m. Refer to the fiber cable manufacturer for multimode distance specifications.

♦ Single-Fiber converters must be used in pairs. The Tx wavelength on one end has to match the Rx wavelength on the other.

© 2010 Omnitron Systems Technology, Inc. All rights reserved. FlexPoint is a Trademark of Omnitron Systems Technology, Inc. Trademarks are owned by their respective companies. Specifications are subject to change without notice. 091-04700-001D 9/10

